

PowerLine IC-E Series

Laser markers for the
semiconductor industry

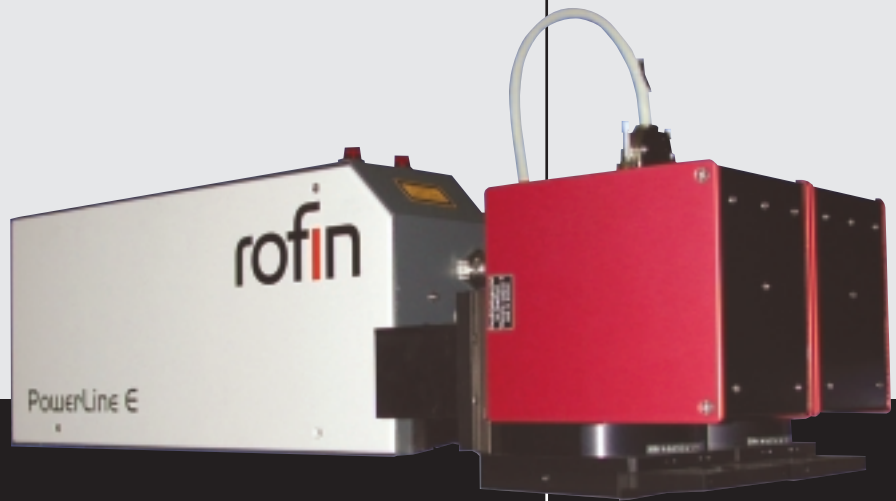

Fast ■

Precise ■

Flexible ■

WE
THINK
LASER

Specialized solution for semiconductor laser marking

Lasers of the PowerLine IC-E series have been exclusively designed for marking electronic components. Precise beam power control and fast laser pulse repetition rates result in high-contrast marking at minimum and steadily controlled material penetration depths of less than 25 micrometers. The reliable hardware guarantees trouble-free operation and low maintenance costs.

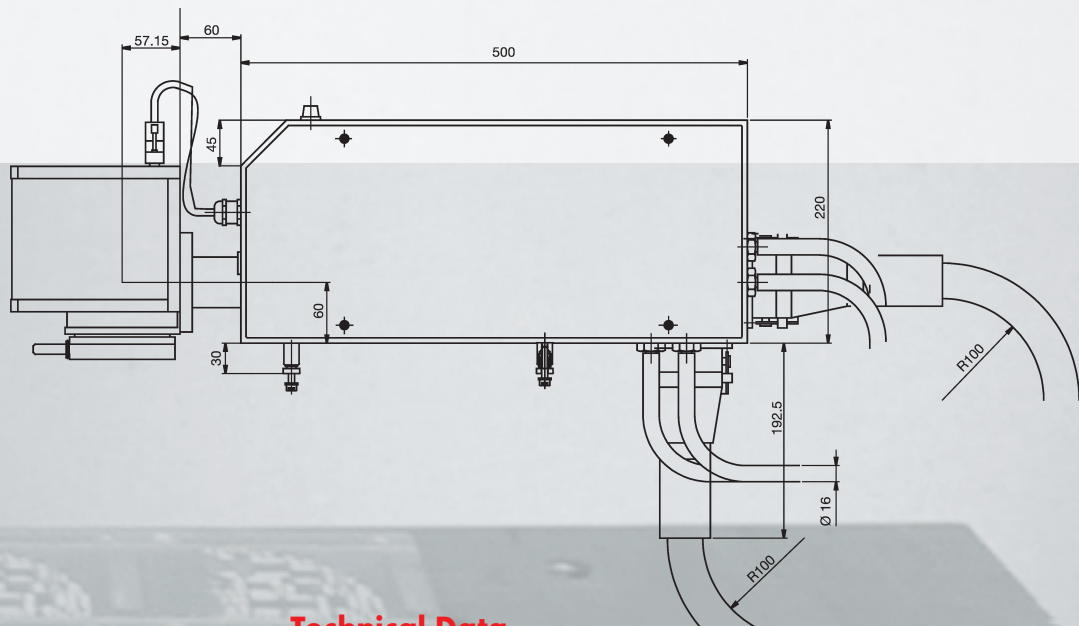

Technical Data

Laser head

Wave length:	1064 / 532 nm
Characters/second:	up to 800 with single head, up to 1,100 with double head
Dimensions (LxWxH):	500 x 118 x 220 mm
Weight:	approx. 19 kg
Safety class:	IP 54

Marking unit

Marking field size:	180 x 180 mm (single head) / 300 x 180 mm (double head)
Focal length:	254 mm
Dimensions (LxWxH):	175 x 118 x 166 mm
Weight:	approx. 2,7 kg
Safety class:	IP 54

Supply unit

Dimensions (LxWxH), Weight:	
19" components: electric unit:	450 mm x 19" x 5 HE; 34,5 kg
cooling unit:	580 mm x 19" x 6 HE; 50 kg
Supply cabinet „Basic“:	(D x W x H) 630 x 600 x 600 mm, 115 kg
Electric supply:	230 V \pm 10%, 50 Hz / 60 Hz, single phase
Power consumption:	max. 1.9 kVA
Safety class:	IP 54, IP 20 (19" units)

Fast

Speeds of up to 800, with double head even up to 1,100 characters/second enable rapid marking of large batch sizes. Line widths are selectable from less than 40 to more than 160 micrometers to meet individual requirements.

Precise

Minimum material penetration at high contrast: with less than 25 μm /1 mil of penetration depth, the lasers of the PowerLine IC-E series are able to mark even the most sensitive components and almost all materials used in semiconductor manufacturing such as mould components, silicons, epoxy, ceramics, etc.

Flexible

A compact laser housing, no external cooling, easy integration into customer-specific machine concepts and a wide range of applications make the PowerLine IC-E series the ideal laser marking solution for the semiconductor industry. The available wavelengths (1064 nm and 532 nm) increase the variety of materials that can be marked.



Source: Infineon Technologies AG



Source: Infineon Technologies AG

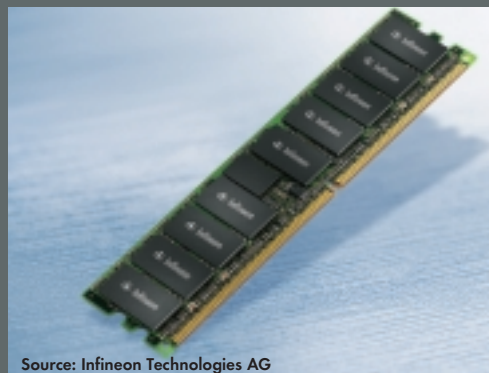

Source: Infineon Technologies AG

ROFIN-SINAR Laser GmbH
Neufeldstraße 16/Günding
D-85232 Bergkirchen
Tel: +49(0)8131-704-0
Fax: +49(0)8131-704-100

MARKING

Carl Baasel Lasertechnik GmbH & Co. KG
Petersbrunner Straße 1b
D-82319 Starnberg
Tel: +49(0)8151-776-0
Fax: +49(0)8151-776-159

MICRO

ROFIN-SINAR Laser GmbH
Berzeliusstraße 83
D-22113 Hamburg
Tel: +49(0)40-733 63-0
Fax: +49(0)40-733 63-100

MACRO

